

ITEM NO.	PART NUMBER	DESCRIPTION	QTY.
1	2BARW	2BAR UTILITY RACK, FSV, W	1
2	1BARW	1BAR UTILITY RACK, FSV, W	1
3	4UPK4B	UTILITY,4" UPRIGHT KIT,4B	1
4	4UPK2B	UTILITY,4" UPRIGHT KIT,2B	1
5	ULSKB	UTILITY, LADDER STOP KIT	1

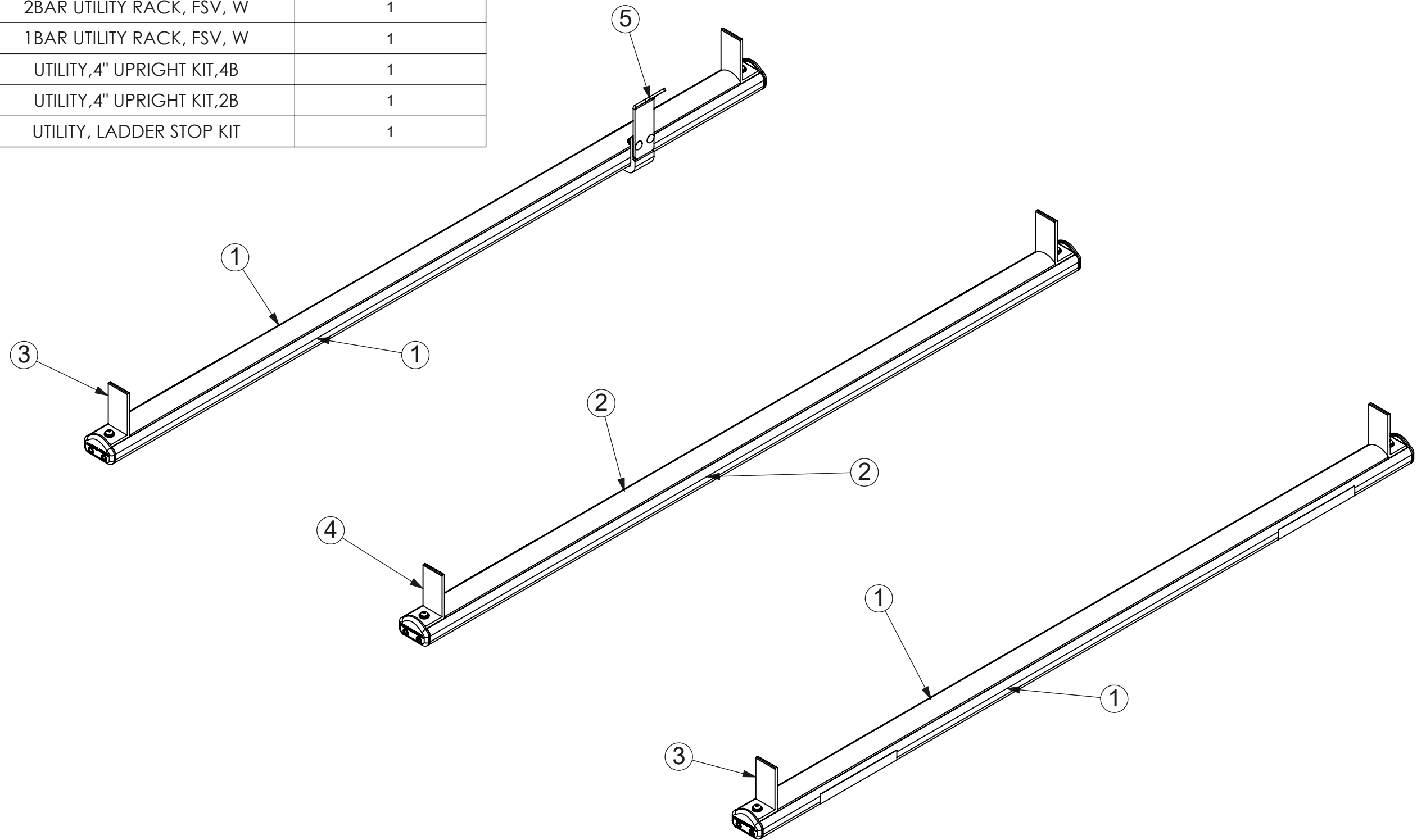

THIS DRAWING IS THE PROPERTY OF ADRIAN STEEL COMPANY AND IS NOT TO BE USED IN ANY MANNER DETRIMENTAL TO THE INTERESTS OF ADRIAN STEEL COMPANY

PRINTED DOCUMENT IS UNCONTROLLED

Sheet 1 of 1

**TOLERANCES & INSPECTION**

**RELEASE & REVISIONS**

**MATERIAL & FINISH**

**PART / PRODUCT IDENTIFICATION**

UNLESS OTHERWISE SPECIFIED  
 ALL BEND ANGLES ARE 90 DEGREES  
 ALL DIMENSIONS ARE IN INCHES.  
 REFERENCE DIMENSIONS (X.XXX)  
 DO NOT REQUIRE INSPECTION

FEATURES	HOLES/SLOTS	ANGLES
0.0 = ± .125	0.0 = ± .062	0° = ± 2°
0.00 = ± .062	0.00 = ± .031	0.0° = ± 1°
0.000 = ± .031	0.000 = ± .015	

Material Thickness: per ASTM Std.  
 Weld Callouts per AWS

INITIAL ECN: **25146**  
 CURRENT ECN: **25146**  
 ECN DESCRIPTION:  
**RELEASE FOR PRODUCTION**  
 REVISED BY: **N/A**

MECHANICAL FINISHING:  
**N/A**  
 PRIMER: **N/A**  
 FINAL FINISH: **NONE NONE**  
**Paint Weight: N/A**  
 MATERIAL TYPE: **ASSM**

 <b>ADRIAN STEEL®</b>		ADRIAN STEEL COMPANY 906 JAMES STREET, ADRIAN, MI 49221	REVISION LEVEL <b>A</b>
MAT'L USED: <b>ASSEMBLY</b>	DESIGNED BY: <b>Z. BURK</b>		
DESCRIPTION: <b>3BAR FSV, 4" UPRIGHTS, W</b>			
WEIGHT (Lbs.): <b>35.34</b>	SEGMENT CODE: <b>VLR</b>	PART NUMBER: <b>3B4W</b>	