

ITEM NO.	PART NUMBER	DESCRIPTION	QTY.
1	2BARCW	2BAR UTILITY RACK, CV, W	1
2	URMBK4W	UTILTY,MNT BKT KT,RAIL,4W	1
3	RRKPM	ROOF RAIL KIT, PROMASTER FSV	1
4	PLMDPSMW	PROLIFT,MAX,PS,MR, WHITE	1
5	PLMDDSMW	PROLIFT,MAX,DS,MR, WHITE	1

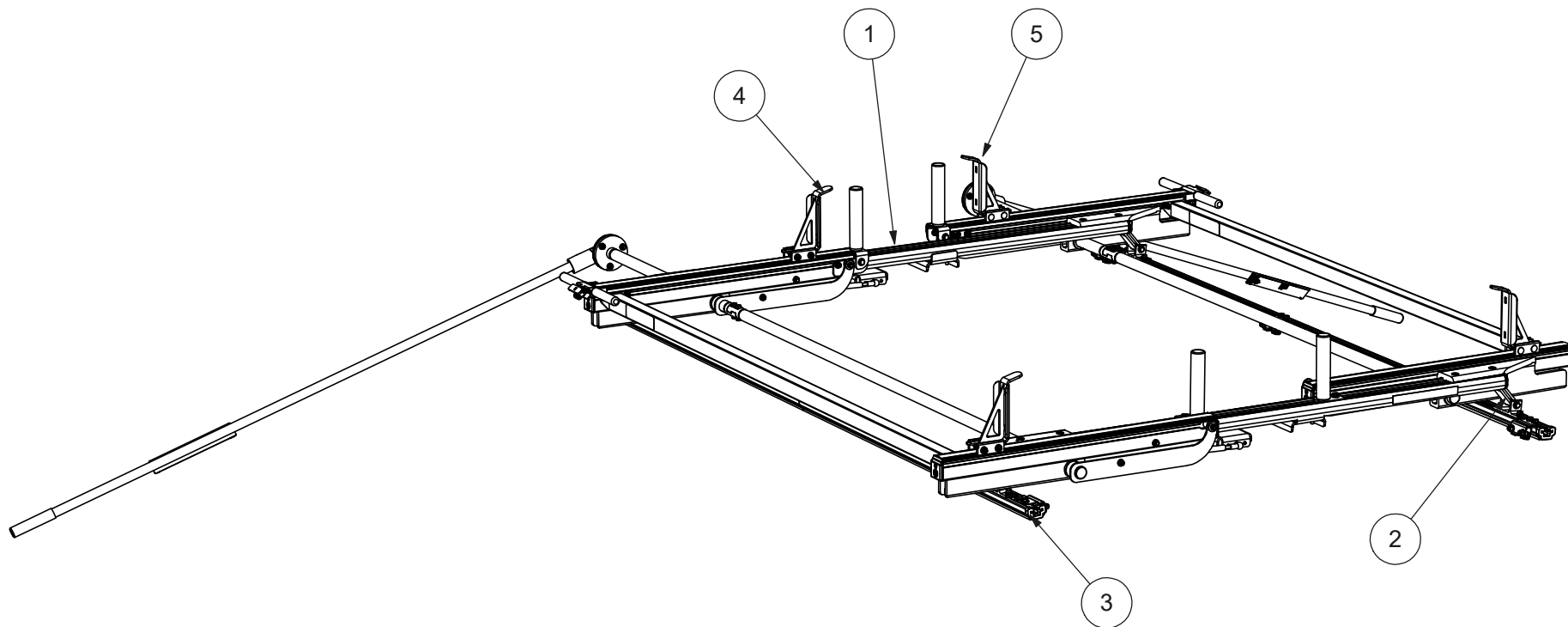

THIS DRAWING IS THE PROPERTY OF ADRIAN STEEL COMPANY AND IS NOT TO BE USED IN ANY MANNER DETRIMENTAL TO THE INTERESTS OF ADRIAN STEEL COMPANY

PRINTED DOCUMENT IS UNCONTROLLED

Sheet 1 of 1

**TOLERANCES & INSPECTION**

**RELEASE & REVISIONS**

**MATERIAL & FINISH**

**PART / PRODUCT IDENTIFICATION**

UNLESS OTHERWISE SPECIFIED  
ALL BEND ANGLES ARE 90 DEGREES  
ALL DIMENSIONS ARE IN INCHES.  
REFERENCE DIMENSIONS (X.XXX)  
DO NOT REQUIRE INSPECTION

FEATURES	HOLES/SLOTS	ANGLES
0.0 = ± .125	0.0 = ± .062	0° = ± 2°
0.00 = ± .062	0.00 = ± .031	0.0° = ± 1°
0.000 = ± .031	0.000 = ± .015	

Material Thickness: per ASTM Std.  
Weld Callouts per AWS

INITIAL ECN: **25488**

CURRENT ECN: **25488**

ECN DESCRIPTION:  
**RELEASE FOR PRODUCTION**

REVISED BY:

MECHANICAL FINISHING:  
**N/A**

PRIMER: **N/A**

FINAL FINISH: **NONE NONE**

**Paint Weight: N/A**

MATERIAL TYPE: **ASSM**

<b>ADRIAN STEEL</b> ADRIAN STEEL COMPANY 906 JAMES STREET, ADRIAN, MI 49221	DESIGNED BY: <b>B.Southward</b>	REVISION LEVEL <b>A</b>
	MAT'L USED: <b>ASSM</b>	
DESCRIPTION: <b>DBL MAX-DROP DOWN PM 118 LR</b>		
WEIGHT (Lbs.): <b>189.37</b>	SEGMENT CODE: <b>VLR</b>	PART NUMBER: <b>PLM63PL</b>