

ITEM NO.	PART NUMBER	DESCRIPTION	QTY.
1	2BARCW	2BAR UTILITY RACK, CV, W	1
2	CRMBK4W	COMPCT,MNT BKT KT,RAIL,4W	1
3	PLSDPSCW	PROLIFT,STD,COMPCT,PS,W	1
4	RRKPMC	ROOF RAIL KIT, PMC	1
5	GL-CVDS	GRIP LOCK,COMPACT VAN,DS	1

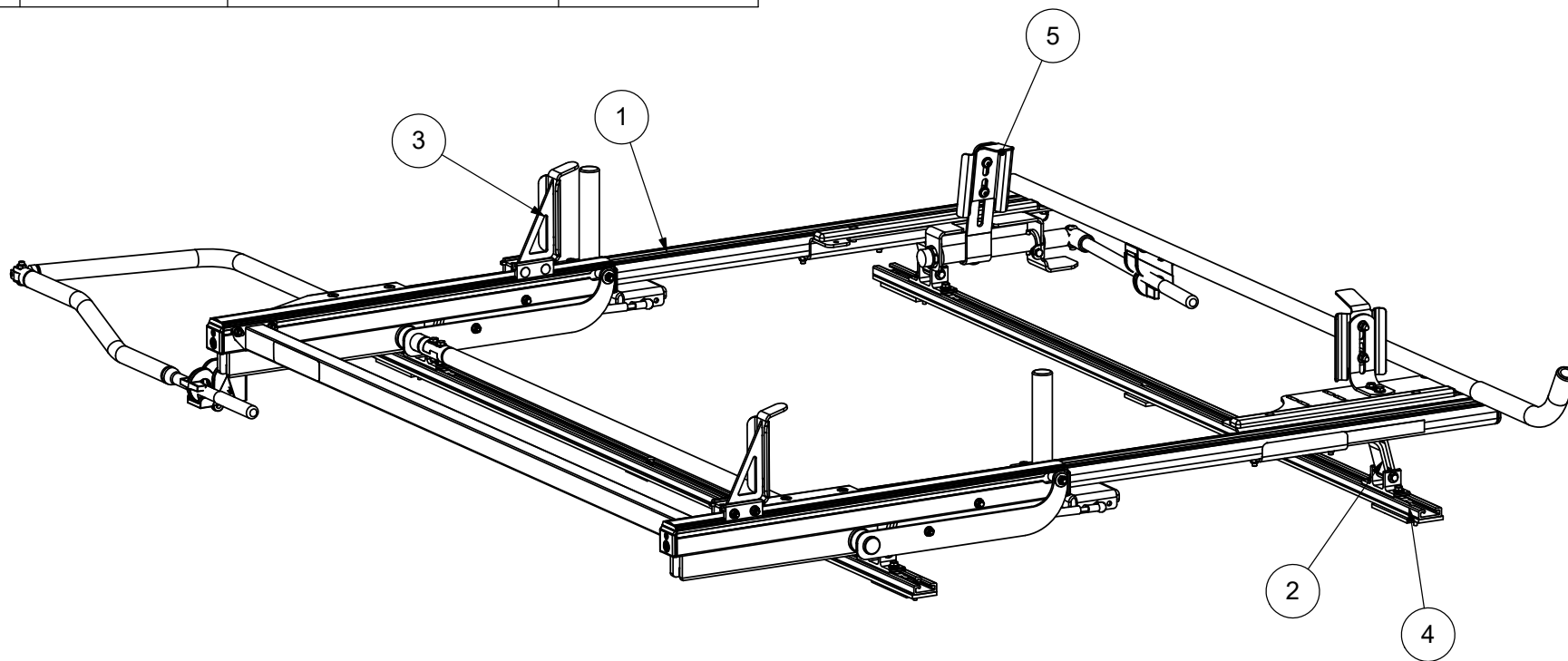

THIS DRAWING IS THE PROPERTY OF ADRIAN STEEL COMPANY AND IS NOT TO BE USED IN ANY MANNER  
DETRIMENTAL TO THE INTERESTS OF ADRIAN STEEL COMPANY

PRINTED DOCUMENT IS UNCONTROLLED

Sheet 1 of 1

### TOLERANCES & INSPECTION

### RELEASE & REVISIONS

### MATERIAL & FINISH

### PART / PRODUCT IDENTIFICATION

UNLESS OTHERWISE SPECIFIED  
ALL BEND ANGLES ARE 90 DEGREES  
ALL DIMENSIONS ARE IN INCHES.  
REFERENCE DIMENSIONS (X.XXX)  
DO NOT REQUIRE INSPECTION

FEATURES	HOLES/SLOTS	ANGLES
0.0 ± .125	0.0 ± .062	0° ± 2°
0.00 ± .062	0.00 ± .031	0.0° ± 1°
0.000 ± .031	0.000 ± .015	

Material Thickness: per ASTM Std.  
Weld Callouts per AWS

INITIAL ECN: **22942**

CURRENT ECN: **22942**

ECN DESCRIPTION:  
**Released for Production**

REVISED BY:

MECHANICAL FINISHING:  
**N/A**

PRIMER: **N/A**

FINAL FINISH: **NONE NONE**

**Paint Weight: N/A**

MATERIAL TYPE: **ASSM**

 <b>ADRIAN STEEL</b> <sup>®</sup>		ADRIAN STEEL COMPANY 906 JAMES STREET, ADRIAN, MI 49221		REVISION LEVEL <b>A</b>
		MAT'L USED: <b>ASSM</b>	DESIGNED BY: <b>B.Southward</b>	
DESCRIPTION: <b>Combo Drop Down PMC</b>				
WEIGHT (Lbs.): <b>141.25</b>	SEGMENT CODE: <b>VLR</b>	PART NUMBER: <b>PLS64PMC</b>		