

ITEM NO.	PART NUMBER	DESCRIPTION	QTY.
1	CRMBK4W	COMPCT,MNT BKT KT,RAIL,4W	1
2	RRKTCL	ROOF RAIL KIT, TC LWB	1
3	PLSDPSCW	PROLIFT,STD,COMPCT,PS,W	1
4	PLSDDSCW	PROLIFT,STD,COMPCT,DS,W	1
5	2BARTOPW	2BAR UTILITY RACK, TOP, W	1

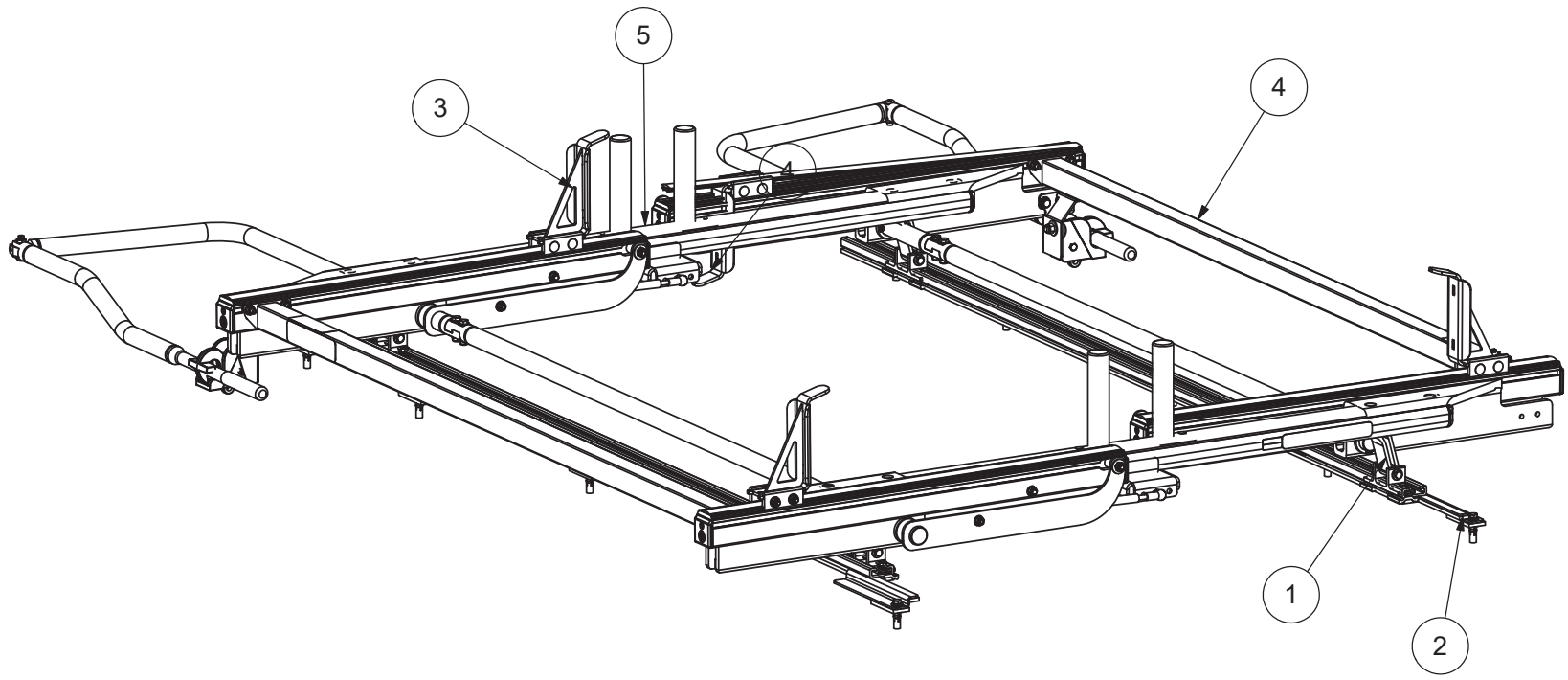

THIS DRAWING IS THE PROPERTY OF ADRIAN STEEL COMPANY AND IS NOT TO BE USED IN ANY MANNER DETRIMENTAL TO THE INTERESTS OF ADRIAN STEEL COMPANY

PRINTED DOCUMENT IS UNCONTROLLED

Sheet 1 of 1

TOLERANCES & INSPECTION		
UNLESS OTHERWISE SPECIFIED		
ALL BEND ANGLES ARE 90 DEGREES		
ALL DIMENSIONS ARE IN INCHES.		
REFERENCE DIMENSIONS (X.XXX) DO NOT REQUIRE INSPECTION		
FEATURES	HOLES/SLOTS	ANGLES
0.0 = ± .125	0.0 = ± .062	0° = ± 2°
0.00 = ± .062	0.00 = ± .031	0.0° = ± 1°
0.000 = ± .031	0.000 = ± .015	
Material Thickness: per ASTM Std. Weld Callouts per AWS		

RELEASE & REVISIONS
INITIAL ECN: 22942
CURRENT ECN: 23451
ECN DESCRIPTION: Remove 2BARCW Add 2BARTOPW
REVISED BY: BDS

MATERIAL & FINISH
MECHANICAL FINISHING: N/A
PRIMER: N/A
FINAL FINISH: NONE NONE
Paint Weight: N/A
MATERIAL TYPE: ASSM

PART / PRODUCT IDENTIFICATION		
 ADRIAN STEEL [®]		ADRIAN STEEL COMPANY 906 JAMES STREET, ADRIAN, MI 49221
MAT'L USED: ASSM	DESIGNED BY: B.Southward	
DESCRIPTION: Dual Sided Drop Down TC 120"WB		
WEIGHT (Lbs.): 178.14	SEGMENT CODE: VLR	PART NUMBER: PLSD63TCL
		REVISION LEVEL: B